



STEVE 'N' SEAGULLS TECHNICAL RIDER 2019

UPDATED November 11, 2019

- PA:** Factory-made and professional quality PA system (preferred manufacturers: L'Acoustics, d&b, Nexo, JBL, Meyer, Martin, EAW). 105 dBA/slow measured from the mixing spot without distortion or system limiting. The whole soundsystem should be optimized for the venue and all possible separate sends in addition to the main left and right (front fills, under balcony fills, delay systems, etc.) are to be time aligned and equalized by a competent system engineer. The system must be free of hums and noises and in good working condition at load-in time.
- FOH:** We bring our own Allen & Heath dLive C1500 mixing console and Allen & Heath CDM32 MixRack. **We need 2 (two) quality STP Cat5e/Cat6/Cat7 cables with EtherCon connectors between FOH and stage. Maximum cable length 100 metres (300'). If possible, not more than 75 metres (240').** FOH position must be located in the middle of the audience and in the center of the stereo image of PA system with a good overview of the stage area. It must be on the same level as the audience is standing and cannot be under a balcony, on a balcony or at the back wall of the venue. We need at least 2 x 2 m sized working area restricted from the audience with the help of security staff if necessary. **Ideal dimensions for FOH work surface are L 135 cm x W 75 cm x H 80 cm. Also we need 2 (two) tall boom stands in FOH position.**
- MON:** We bring our own Sennheiser EW 300 IEM G3 system, that needs 3 (three) frequencies from **Range B 626-668 MHz**. IEMs are mixed from FOH: 2 (two) mono mixes, 2 (two) stereo mixes + 1 (one) wired stereo mix for the drummer. If those frequencies cannot be used, the organizer should arrange alternative system for IEMs. **In an emergency situation** band can play with stage monitors. In this case we need 5 (five) professional quality wedges (same brand and model) and a separate monitor console with a competent English speaking sound engineer to operate it. There must be an intercom system between MON and FOH positions. We need 1 (one) tall boom stand for directional antenna on stage.
- STAGE:** The size of the stage should be at least 6 x 4 m. If possible, 3 x 2 m riser for the drummer.
- LIGHTS:** We don't have our own lighting technician, so we need 1 (one) English speaking professional to operate lights during the show.
- POWER:** Our equipment are working on 100-240V AC, 50/60 Hz. We provide all the necessary power adapters for each country. All the needed power outlets are shown in the stage plot.
- OTHER:** The band is travelling with 1 (one) FOH engineer. There is always needed at least 1 (one) competent person with the locally provided or house sound system to be present from the time of the load-in. Also till the end of the show if needed. He/she must have a knowledge of the PA / lighting system and venue in question. **ALWAYS check the latest version of technical rider from www.anttilaitila.com/snstechrider**

On technical issues please don't hesitate to contact us.

Antti Laitila	FOH Engineer	+358 40 770 4270	antti@anttilaitila.com
Viljam Hänninen	Band	+358 41 430 6815	sivijoha@gmail.com

STEVE 'N' SEAGULLS INPUT LIST 2019

UPDATED November 11, 2019

CH	INSTRUMENT	MICROPHONE / OUTPUT DEVICE	+48V	STAND
01	BD IN	Shure Beta 91A	X	
02	BD OUT	Sennheiser e902		S/B
03	SNARE TOP	Beyerdynamic M 201 TG		Clamp
04	SNARE BOTTOM	Sennheiser e604		Clip
05	HH	RØDE NT5	X	S/B
06	PANDEIRO	RØDE NT5	X	Clamp
07	TIMBALE	Heil Sound PR28		Clip
08	RACK TOM 10"	Heil Sound PR28		Clip
09	FLOOR TOM 14"	Sennheiser e902		Clip
10	OH STAGE RIGHT	AKG C214	X	T/B
11	OH STAGE LEFT	AKG C214	X	T/B
12	UPRIGHT BASS	Radial Tonebone		
13	ACOUSTIC GUITAR 1	Telefunken TDA-2 Active Stereo DI	X	
14	ACOUSTIC GUITAR 2	Telefunken TDA-2 Active Stereo DI	X	
15	MANDOLIN 1	BSS AR-133 DI	X	
16	MANDOLIN 2	Telefunken TDA-2 Active Stereo DI	X	
17	BANJO 1	Telefunken TDA-2 Active Stereo DI	X	
18	BANJO 2	Telefunken TDA-2 Active Stereo DI	X	
19	ACCORDION	AKG C518 M	X	
20	KEYBOARD L	Radial ProD2 Passive Stereo DI		
21	KEYBOARD R	Radial ProD2 Passive Stereo DI		
22	DRUM VOC SKUBU	Telefunken M81 SH		T/B
23	LEAD VOC REMMEL	Telefunken M81		T/B
24	BASS VOC JAMPPA	Telefunken M81		T/B
25	BANJO VOC HERMAN	Telefunken M81		T/B
26	CLICK	From drummer, stage right.		

On technical issues please don't hesitate to contact us.

Antti Laitila
Viljam Hänninen

FOH Engineer
Band

+358 40 770 4270
+358 41 430 6815

antti@anttilaitila.com
sivijoha@gmail.com

STEVE 'N' SEAGULLS STAGE PLOT 2019

UPDATED November 11, 2019

BACKDROP BIG 14 x 9 m or SMALL 5 x 3 m

STAGE RIGHT

STAGE LEFT

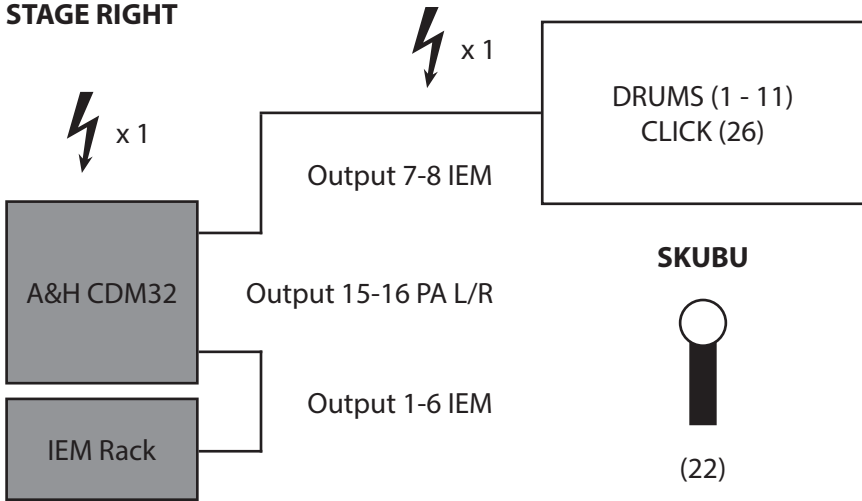

Stagebox and IEM rack can be located both stage left or stage right.

ALWAYS check the latest version of technical rider from www.anttilaitila.com/snstechrider

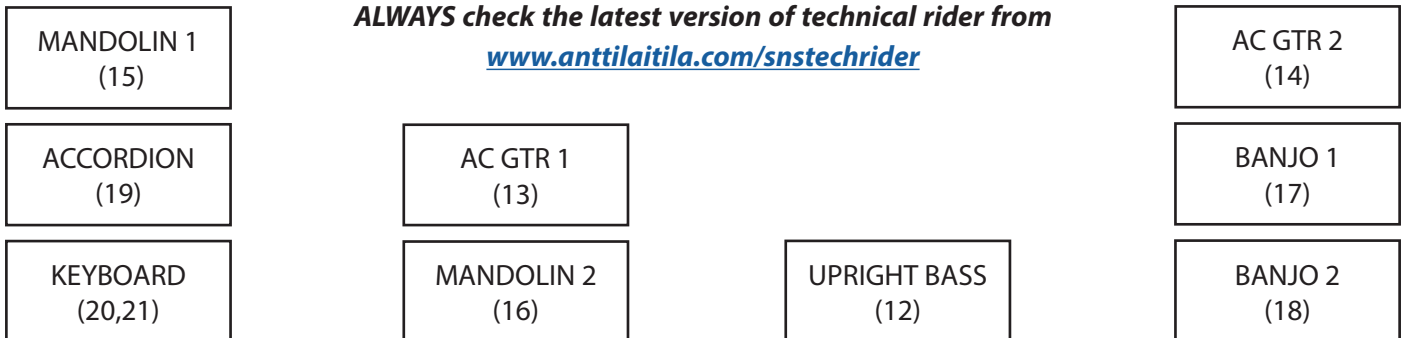

HILTUNEN



REMMEL



(23)



JAMPPA



(24)



HERMAN



(25)



 = Vocal microphone

 = Power outlet

On technical issues please don't hesitate to contact us.

Antti Laitila
Viljam Hänninen

FOH Engineer
Band

+358 40 770 4270
+358 41 430 6815

antti@anttilaitila.com
sivijoha@gmail.com